

m₃ MARSH BELLOFRAM®

Type-2000

Electro-Pneumatic
I/P & E/P
Transducers

Precision
Control
Devices



m₃ T-2000 I/P & E/P Transducers

ISO 9002
certified



incoming supply pressure down to a precise output pressure which is directly proportional to an electrical control signal. The secret to the Type 2000's precise, reliable performance under a variety of demanding environmental conditions is a patented piezo-ceramic actuator with many industry-wide firsts.

The Type 2000 has been designed to meet the electropneumatic needs of the world:

- Field-selectable inputs and direct/reverse/split ranging
- Multiple input/output/mounting configurations
- Precise, reliable performance under extreme conditions of temperature, vibration, orientation, supply pressure changes, supply voltage changes, RFI/EMI, humid / oil-laden media, and corrosive surroundings
- Agency Approvals (pending)

PRINCIPLE OF OPERATION

The Type 2000 I/P and E/P transducers utilize closed-loop pressure feedback-control for precision pressure output and minimized effects of temperature, supply pressure changes, supply voltage changes, and mounting angle.

Supply pressure is reduced by the supply valve to provide an output pressure which is internally routed to a precision temperature compensated piezoresistive pressure sensor. Supply pressure is also routed to an externally removable orifice which provides a reduced pilot pressure to a chamber containing a servo diaphragm and nozzle. Pilot pressure is controlled by modulating the gap between the face of a nozzle and an adjacent piezo-ceramic actuator, which is part of a unique patented (pending) mechanism.

The piezo-ceramic actuator serves as a control link between electrical input and pressure output as follows:

- The input current (I/P) or voltage (E/P) signal is conditioned to provide a normalized control signal directly proportional to the desired pressure output.
- Simultaneously the output of the pressure sensor is amplified and conditioned to produce a feedback signal.
- The sum of the control signal and the feedback signal produce a command signal which is delivered as a DC voltage to the piezo-ceramic actuator.
- As voltage increases, the force applied by the actuator increases, so as to restrict nozzle bleed and thus increase pilot pressure.
- Increased pilot pressure applied to the servo diaphragm directly causes opening of the supply valve and an increase in the output pressure until the output feedback signal and control signal combine to produce the correct command signal.



APPLICATIONS

The Type 2000's precisely regulated pneumatic output can be used to operate:

- Valve actuators
- Louver and damper actuators
- Valve positioners
- Relays
- Clutches and brakes
- Controllers
- Air cylinders

INDUSTRY APPLICATIONS INCLUDE:

- Chemical & Petrochemical Industries
- Petroleum production
- Pipeline Transmission
- Electric Utilities
- Water & Wastewater Systems
- Pulp & Paper
- Textiles
- Semiconductor Industry
- Food & Beverage
- Environmental Control Systems
- Construction Equipment
- Agricultural Equipment
- Machine Tool
- Material Handling
- Automotive Testing & Assembly
- Medical Equipment

DESCRIPTION



FINE-TUNING YOUR APPLICATION

For optimal performance in your application, the calibration of the Type 2000 can be fine-tuned in the field. An easily-removeable cover provides access to the isolated electronics. All potentiometers, connections, jumpers, and switches are clearly marked on the circuit board or on the handy chart located on the inside of the cover. The three elements of calibration (Gain, Zero, and Span) are described below. Consult the Type 2000 User's Manual for detailed calibration procedures, cautions, and instrumentation requirements.

GAIN (DAMPING) ADJUSTMENT

The output response of the Type 2000 can be optimized for varying downstream volumes by adjusting the system gain of the control circuit. Adjust the Gain Pot counterclockwise for increased gain; clockwise for increased oscillation damping. For maximum allowable gain in your application, the pot should be turned clockwise until oscillation just disappears.

ZERO & SPAN ADJUSTMENTS

The Type 2000 contains multi-turn Coarse-Zero, Fine-Zero, and Span adjustment potentiometers which are clockwise positive. Adjustment of either Zero Pot changes the unit's minimum output while the Span Pot changes the maximum output. The adjustments are interactive, so it may take iterations to reach the desired calibration.

WIDE RANGEABILITY

The Type 2000 can be field calibrated to pressure ranges other than the standard ones by combinations of recalibration, pressure range switching, and split high/low ranging. A unit should not be switched to a range outside its pressure sensor family (eg., a 0-15 psig can be switched to a 3-15 psig, but not to 0-30 psig). **(Caution: Do not exceed the range of the onboard pressure sensor.)** For example, the easiest way to recalibrate a 0-30 psig unit to 3-15 psig would be to change the switch setting to 3-27 psig, then switch to split range low.

FIELD-SELECTABLE FEATURES

Onboard switches allow the user to easily reconfigure the Type 2000 for any of several electrical inputs, direct/reverse acting, or output split-ranging high/low. Fine tuning of the unit's calibration may be necessary after a reconfiguration.

DIRECT/REVERSE ACTING

Direct Acting transducers regulate to their minimum output when supplied with minimum input; maximum out with maximum in. Reverse Acting transducers regulate to their maximum output at minimum input.

SPLIT RANGING HIGH & LOW

The Type 2000 can be configured to regulate either half (top or bottom) of its normal output range, when supplied with its normal full-ranging electrical input. For example, a 0-10V 0-30psi unit set to split range low will regulate 0-15psi @ 0-10V. It will regulate 15-30psi @ 0-10V if set to split range high.

HAZARDOUS AREA & USAGE CLASSIFICATION

INTRINSIC SAFETY: Approved for Class I, Division 1 and 2, Groups A, B, C, D; Class II, Division 1 and 2, Groups E, F, and G; and Class III for hazardous locations per ATEX directive.

NEMA 4X: Pending approval (water tight, dust tight, and corrosion-resistant).

IP66: Pending approval.

(NEMA 4X & IP66 not available on Terminal Block Models.)

EXPLOSION PROOF (E MODEL ONLY): Pending approval for: Class I, Division 1 and 2, Groups A, B, C, and D; Class II, Divisions 1 and 2, Groups E, F, and G; and Class III.

CE (CONDUIT CONNECTOR ONLY): EN 50081-1 Residential, commercial & light industry; EN-50082-2 Heavy Industrial

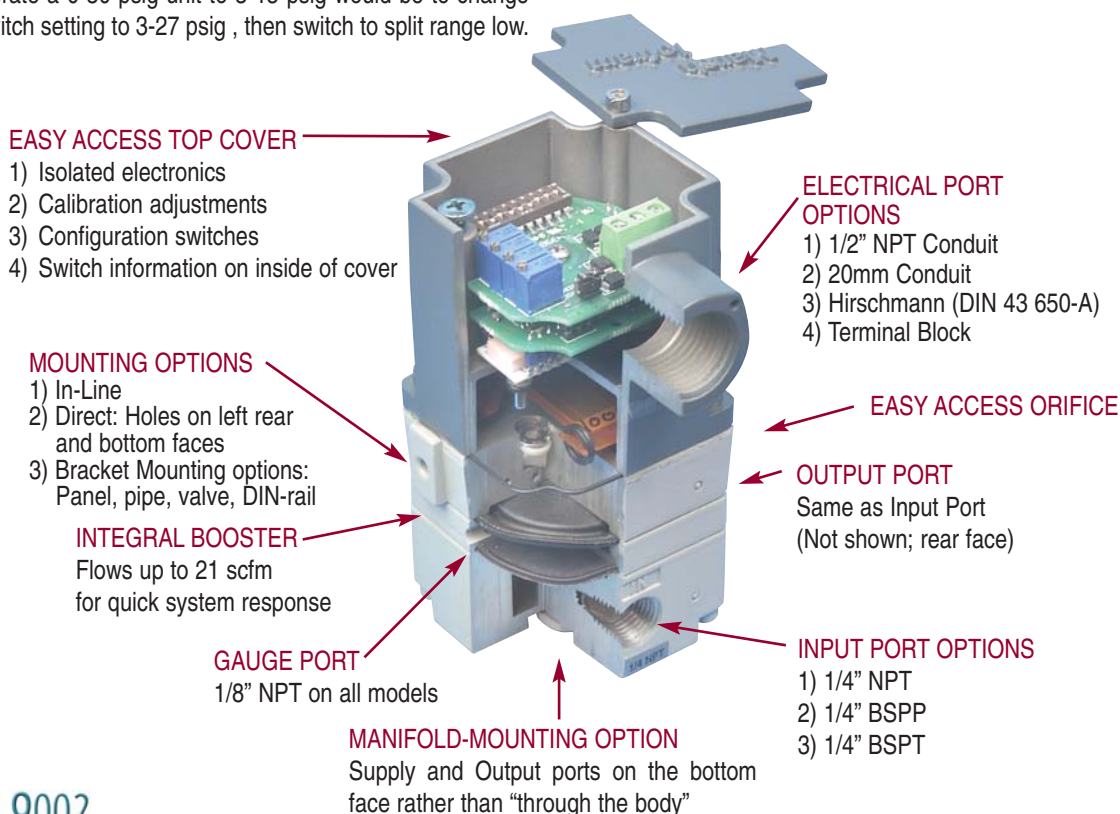

SPECIFICATIONS

ACCURACY 0.1% of full-scale output typical (0.25% guaranteed); includes effects of hysteresis, dead band, and repeatability

ELECTRICAL
Inputs Switch-Selectable
 4-20mA. 0-5, 1-5, 1-9, 1-10, or 0-10VDC

Connections 1/4" NPT or 20mm Conduit
 DIN Hirschmann (S model only)
 External Terminal Block (S model only)

Power Supply 5-28VDC (with voltage inputs only)

Direct/Reverse Acting Switch-Selectable

PNEUMATIC
Outputs 0-2, 0-5, 0-15, 3-15, 1-17, 0-30, 6-30, 3-27, 0-60, 0-100, or 120 psig
 0-0.1, 0-0.3, 0-1.0, 0.2-1.0, 0.07-1.2, 0-2.1, 0.4-2.1, 0.2-1.9,
 0-4.1, 0-6.9, 0-8.3 BAR

Ports (Input/Output) 1/4" (NPT, BSPT, or BSPP threads)
 Bottom-ported for Manifold Mounting

Ports (Gauge) 1/8" NPT

Supply From 5 psi (0.3 BAR) above output, up to 140 psi (9.7 BAR) maximum (20 psi [1.4 BAR] minimum)

Split-Ranging Switch-Selectable, Full-Range or Split-Range High or Split-Range Low

Consumption 4 scfh maximum (1.9 LPM)

| Flow Capacity | RANGE | | SENSOR | | FLOW | |
|---------------|-------|----------|--------|-----|------|-----|
| | psig | BAR | psig | BAR | scfm | LPM |
| | 0-2 | 0-0.1 | 2 | 0.1 | 4 | 113 |
| | 0-5 | 0-0.3 | 5 | 0.3 | 11 | 312 |
| | 0-15 | 0-1.0 | 15 | 1.0 | 19 | 538 |
| | 3-15 | 0.2-1.0 | 15 | 1.0 | 19 | 538 |
| | 1-17 | 0.07-1.2 | 15 | 1.0 | 19 | 538 |
| | 0-30 | 0-2.1 | 30 | 2.1 | 21 | 595 |
| | 3-27 | 0.2-1.9 | 30 | 2.1 | 21 | 595 |
| | 6-30 | 0.4-2.1 | 30 | 2.1 | 21 | 595 |
| | 0-60 | 0-4.1 | 50 | 3.5 | 21 | 595 |
| | 0-100 | 0-6.9 | 100 | 6.9 | 21 | 595 |
| | 0-120 | 0-8.3 | 100 | 6.9 | 21 | 595 |

(Typical Flow @ 140 psi (9.7 BAR) in and maximum out)

Exhaust Capacity 3 SCFM (85 LPM) @ 5 psig (0.3 BAR) above setpoint (0-15 psig range unit set at mid range)

STABILITY
 Supply Voltage Effect None
 Supply Pressure Effect None
 Vibration Effect <1%FS (+/-1G; 5-1000Hz)
 Mounting Position Effect None
 RFI/EMI CE-compliant
 Temperature Effect 0.02%FS/°F (-40° to 180°F [-40° to 82°C])
 Storage Temperature -40° to 200°F (-40 to 93°C)



**TYPE 2000
EXPLOSION PROOF**

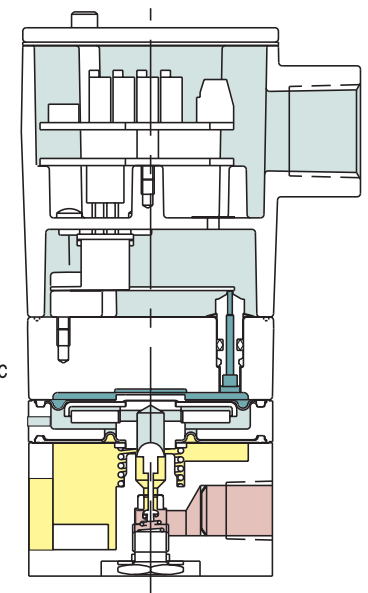

- Atmospheric Pressure
- Pilot Pressure
- Supply Pressure
- Regulated Pressure

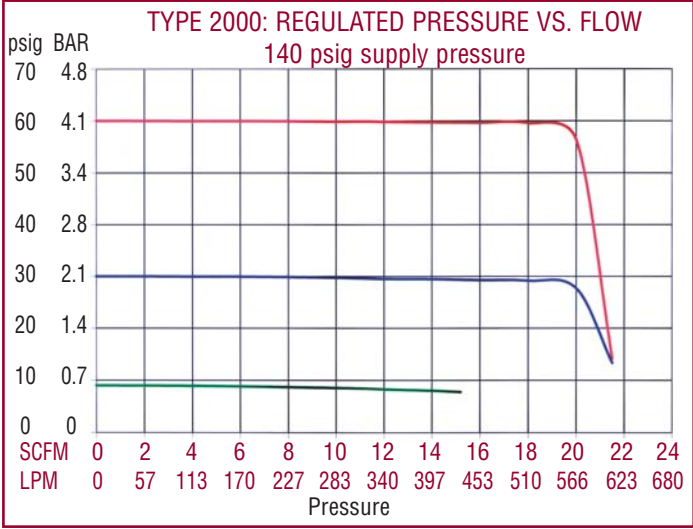

MOUNTING OPTIONS

| Mounting Method | Intrinsically-Safe (S) Model | Explosion-Proof (E) Model |
|------------------|------------------------------|---------------------------|
| In-Line | Yes | Yes |
| Direct Mounting | Side or Bottom Holes | Side or Bottom Holes |
| Panel Bracket | Supplied | Accessory |
| Valve Bracket | Accessory | Supplied |
| Pipe Bracket | Accessory | Accessory |
| DIN-rail Bracket | Accessory | Accessory |
| Manifold Plate | Accessory | Accessory |

MOUNTING: The Type 2000 can be mounted in-line, or directly to a panel via mounting holes located in the side and bottom of the unit. In addition, the S model includes a panel-mounting bracket; while the E model includes a valve-mounting bracket. Kits are available for mounting of either model to panel, valve, pipe, or DIN-rail. A custom plate is available for mounting of the bottom-ported version to a manifold. (See Accessories)

ORDERING INFORMATION

Series **2 K** - Model **□ □ □ □** - Electrical Input **□ □ □ □** Pneumatic Output **□ □ □ □** - Specials **0 0**

ACCESSORIES P/N

Enclosure
 S = Intrinsically Safe
 E = Explosion Proof ¹

Electrical Port
 N = 1/2" NPT Conduit
 M = 20mm Conduit
 H = Herschmann ¹
 T = Terminal Block ²

Pneumatic Ports ³
 N = NPT ⁴
 T = BSPT ⁴
 P = BSPP ⁴
 M = Manifold Mount ⁵

Agency Approval
 F = FM/CSA
 C = CENELEC
 N = None

42 = 4-20 mA
 05 = 0-5 V
 15 = 1-5 V
 19 = 1-9 V
 11 = 1-10 V
 01 = 0-10 V

D = Direct Acting
 R = Reverse Acting

F = Full Range
 H = Split Range High
 L = Split Range Low

002 = 0-2 psig 0-0.1 BAR
 005 = 0-5 psig 0-0.3 BAR
 015 = 0-15 psig 0-1.0 BAR
 315 = 3-15 psig 0.2-1.0 BAR
 117 = 1-17 psig 0.07-1.2 BAR
 030 = 0-30 psig 0-2.1 BAR
 630 = 6-30 psig 0.4-2.1 BAR
 327 = 3-27 psig 0.2-1.9 BAR
 060 = 0-60 psig 0-4.1 BAR
 100 = 0-100 psig 0-6.9 BAR
 120 = 0-120 psig 0-8.3 BAR

00 = None

| | |
|--|-------------|
| Panel Mounting Kit | 010-135-000 |
| Valve Mounting Kit | 010-134-000 |
| 2" Pipe Mounting Kit | 010-143-000 |
| (Valve Mounting Kit is required) | |
| DIN Rail Adaptor(2) | 010-115-000 |
| Manifold Adapter Kit | 971-158-000 |
| Filter Kit, 60 microns | 010-139-000 |
| Filter Kit, Coalescing, 0.1 microns | 010-140-000 |
| Filter Element Kit | 010-141-000 |
| (for coalescing filter, package of 10) | |
| Pressure Gauge Kit | 010-138-000 |
| 15 psig (1 BAR) | |
| Pressure Gauge Kit | 010-138-001 |
| 30 psig (2.1 BAR) | |
| Pressure Gauge Kit | 010-138-002 |
| 60 psig (4.1 BAR) | |
| Pressure Gauge Kit | 010-138-003 |
| 160 psig (11 BAR) | |

NOTES:

| | | | |
|---|---|-----------|-----|
| ¹ Availability Matrix | | Enclosure | |
| | | S | E |
| Electrical Port | N | yes | yes |
| | M | yes | yes |
| | H | yes | no |
| | T | yes | no |
| ² NEMA 4X / IP66 not available | | | |
| ³ Gauge Ports = 1/8"NPT on all models | | | |
| ⁴ Threads as specified (Input & Output=1/4") | | | |
| ⁵ Bottom O-Ring Ports | | | |

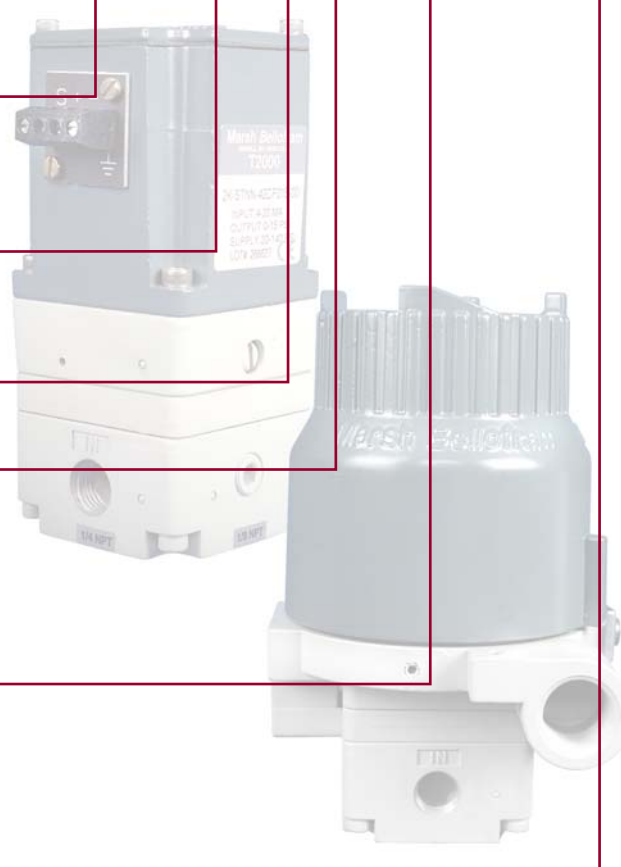

TYPE 2000 SPECIFICATIONS

WIRING CONNECTIONS AND SWITCH POSITIONS

| Terminal Block | I/P Transducer | E/P Transducer |
|----------------|----------------|----------------|
| S | N/C | + Signal |
| + | + Signal | +Power Supply |
| - | - Signal | Common |

| Switch # | 1: psig | BAR | 2 | 3 | 4 | 5 | 6: psig | BAR | 7 | 8 | 9 |
|----------|---------|----------|----------|-----------------|---------------------|----------------|---------|----------|----------------|----------------------|-----|
| ON | 0-2 | 0-0.3 | 1-5 VDC | Split Low | Voltage Input (E/P) | Full Split Low | 0-2 | 0-0.3 | Reverse Acting | Full | I/P |
| | 0-15 | 0-1.0 | 0-5 VDC | | | | 0-15 | 0-1.0 | | | |
| | 3-15 | 0.2-1.0 | | | | | 1-17 | 0.07-1.2 | | | |
| | 1-17 | 0.07-1.2 | | | | | 0-30 | 0-2.1 | | | |
| | 0-30 | 0-2.1 | | | | | 0-60 | 0-4.1 | | | |
| | 3-27 | 0.2-1.9 | | | | | 0-100 | 0-6.9 | | | |
| | 6-30 | 0.4-2.1 | | | | | 0-120 | 0-8.3 | | | |
| | 0-100 | 0-6.9 | | | | | | | | | |
| Switch # | 1: psig | BAR | 2 | 3 | 4 | 5 | 6: psig | BAR | 7 | 8 | 9 |
| OFF | 0-60 | 0-4.1 | 1-9 VDC | Full Split High | Current Input (I/P) | Split High | 3-15 | 0.2-1.0 | Direct Acting | Split Low Split High | E/P |
| | 0-120 | 0-8.3 | 1-10 VDC | | | | 3-27 | 0.2-1.9 | | | |
| | | | 4-20 mA | | | | 6-30 | 0.4-2.1 | | | |

T-2000 DIMENSIONAL DRAWINGS

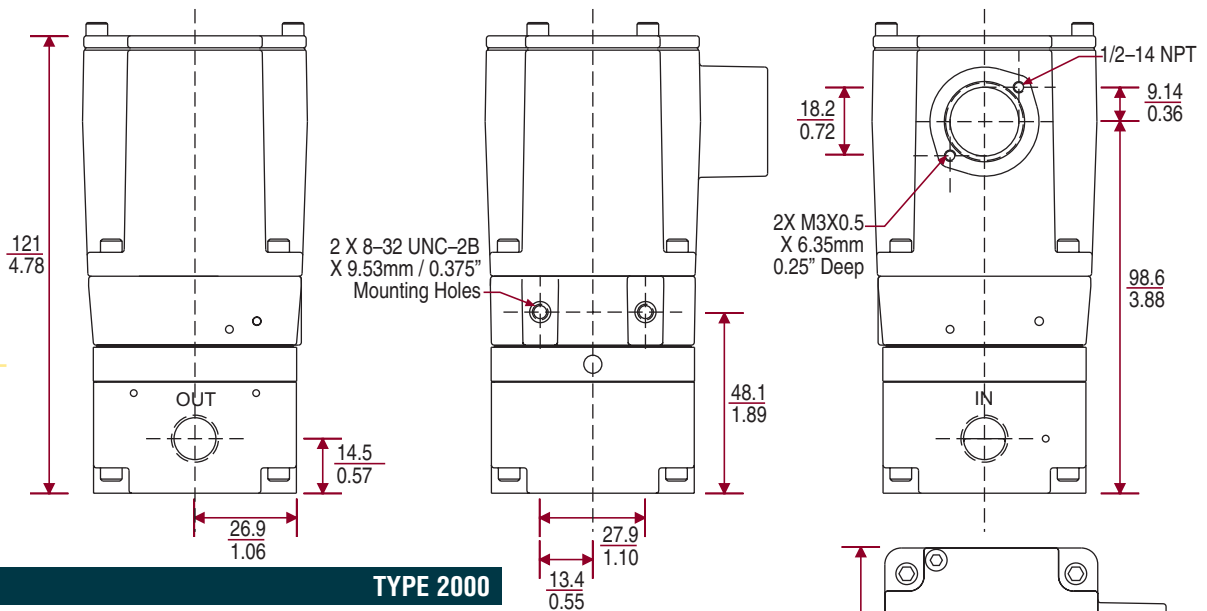

TYPE 2000

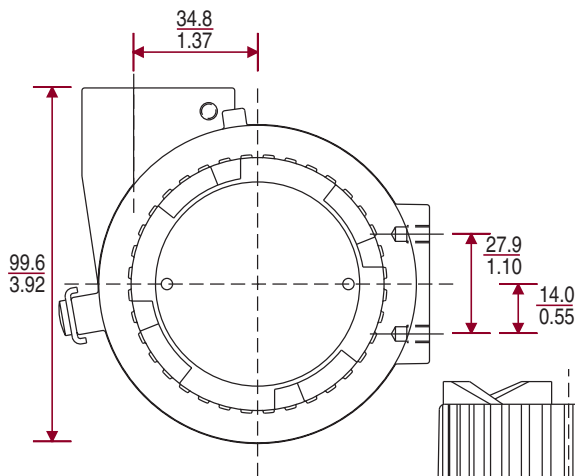

TYPE 2000 EXPLOSION PROOF

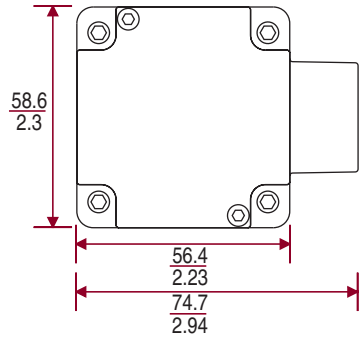

Drawings and dimensions are for reference only.

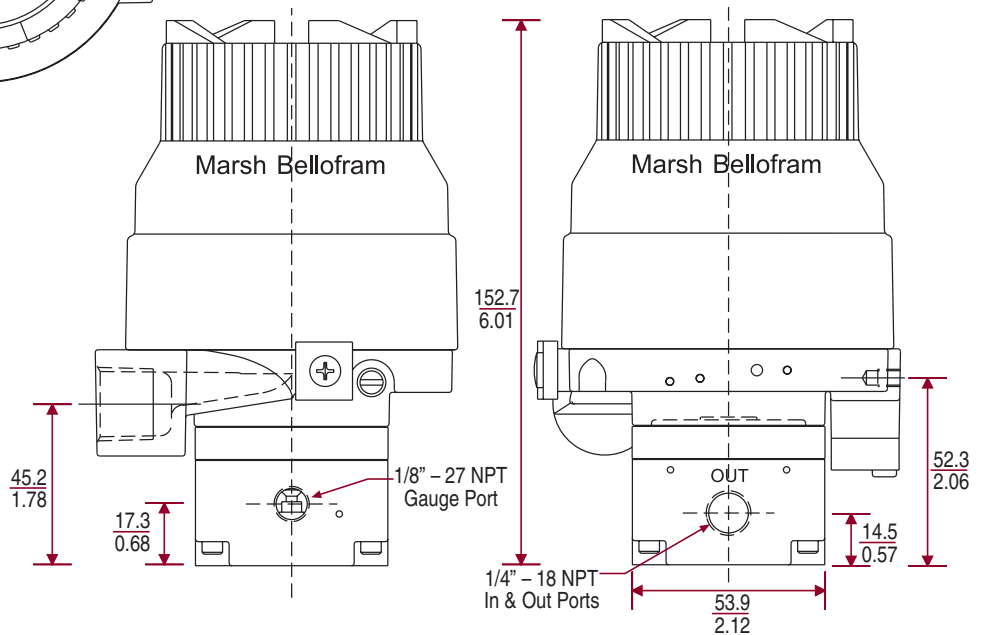

USA

State Route 2, Box 305
Newell, WV 26050
800- 727-5646 or (304)387-1200
FAX (304) 387-4417
info@marshbellofram.com

EUROPE

9 Castle Park, Queens Drive
Nottingham NG2 1AH, UK
Tel +44 (0) 115 993 3300
Fax +44 (0) 115 993 3301
bellofram@aol.com

IMPORTANT NOTICE

Our recommendations, if any, for the use of this product are based on tests believed to be reliable. The greatest care is exercised in the selection of our raw materials and in our manufacturing operations. However, since the use of this product is beyond the control of the manufacturer, no guarantee or warranty, express or implied is made as to such use or effects incidental to such use, handling or possession or the results to be obtained, whether in accordance with the directions or claimed so to be. The manufacturer expressly disclaims responsibility therefor. Furthermore, nothing contained herein shall be construed as a recommendation to use any product in conflict with existing laws and/or patents covering any material or us.

SALES & APPLICATIONS

(800)727-5646 fax:(304) 387-4417

www.marshbellofram.com

